

Alle Maße in mm
All dimensions in mm

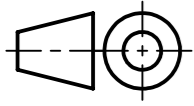

Transportrichtung
Transport direction

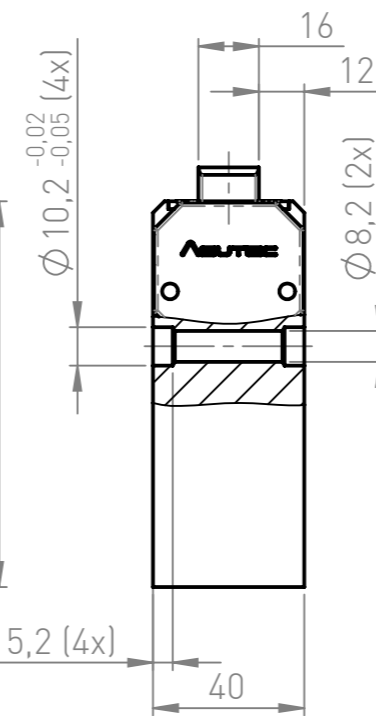
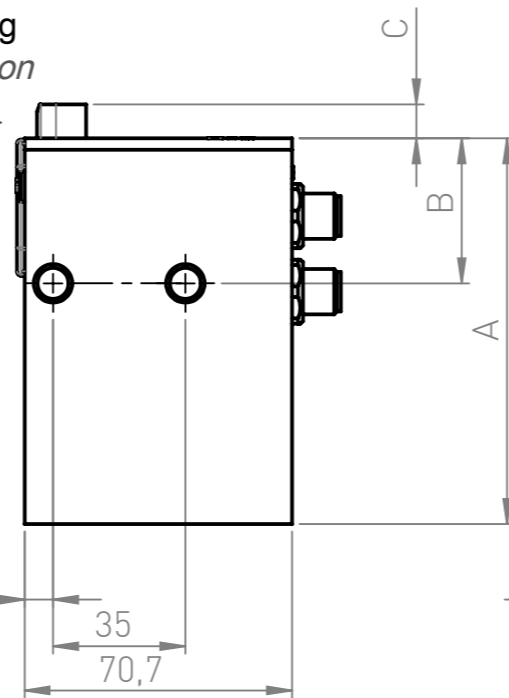
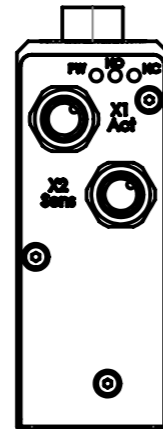

Abgesenkt gezeichnet
Shown in lowered position

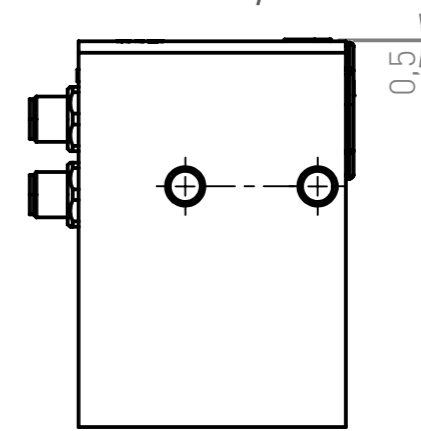

Gewindeabmessungen "-G" Variante
Thread dimensions "-G" variant

ASUEL-150-DW-09-G-G5

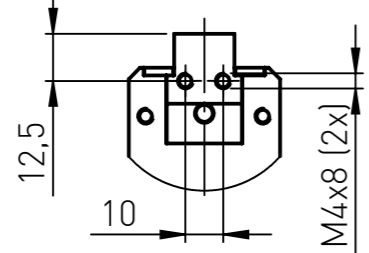

ASUEL-150-DW-15-G-G5

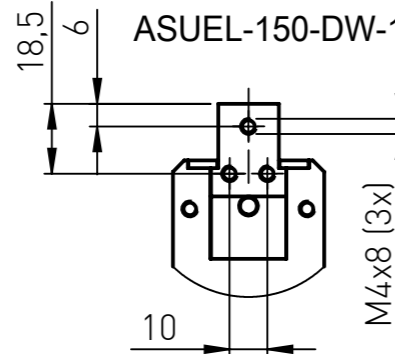

ASUEL-150-DW-25-G-G5

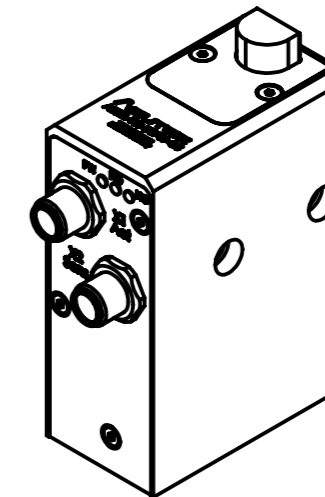
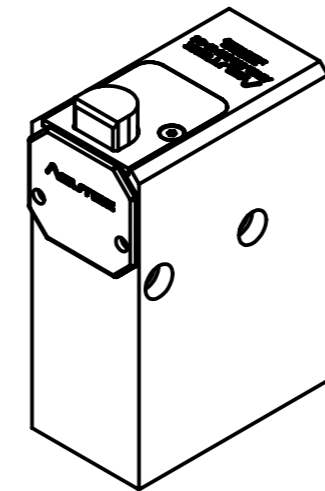
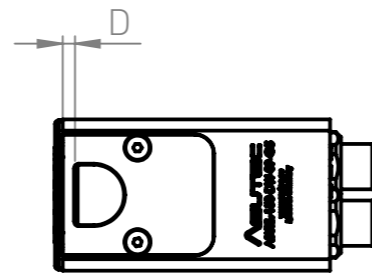
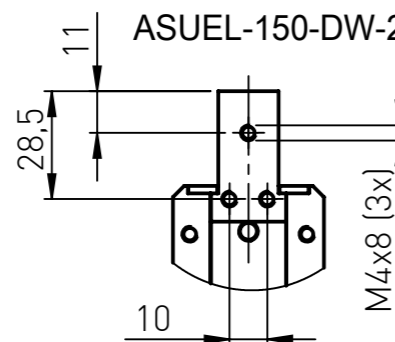

Gerät / Abmessungen	A	B	C	D
ASUEL-150-DW-09-G5	102	38,35	9	3,25
ASUEL-150-DW-09-G-G5	102	38,35	9	0,25
ASUEL-150-DW-15-G5	123	38,35	15	3,25
ASUEL-150-DW-15-G-G5	123	38,35	15	0,25
ASUEL-150-DW-25-G5	148	50	25	3,25
ASUEL-150-DW-25-G-G5	148	50	25	0,25